

*TB 9-6625-2307-35

DEPARTMENT OF THE ARMY TECHNICAL BULLETIN

CALIBRATION PROCEDURE FOR DATA COMMUNICATIONS ANALYZER TS-4281/G AND MODEL TS-4465/G

Headquarters, Department of the Army, Washington, DC
25 February 2004

Distribution Statement A: Approved for public release; distribution is unlimited.

REPORTING OF ERRORS AND RECOMMENDING IMPROVEMENTS

You can improve this manual. If you find any mistakes or if you know of a way to improve these procedures, please let us know. Mail your letter or DA Form 2028 (Recommended Changes to Publications and Blank Forms) directly to: Commander, US Army Aviation and Missile Command, AMSAM-MMC-MA-NP, Redstone Arsenal, AL 35898-5000. A reply will be furnished to you. You may also provide DA Form 2028 information to AMCOM via e-mail, fax, or the World Wide Web. Our fax number is DSN 788-6546 or Commercial 256-842-6546. Our e-mail address is 2028@redstone.army.mil. Instructions for sending an electronic 2028 may be found at the back of this manual. For the World Wide Web, use <https://amcom2028.redstone.army.mil>.

SECTION		Paragraph	Page
	I. IDENTIFICATION AND DESCRIPTION		
	Test instrument identification.....	1	2
	Forms, records, and reports	2	2
	Calibration description	3	2
	II. EQUIPMENT REQUIREMENTS		
	Equipment required	4	2
	Accessories required	5	2
	III. CALIBRATION PROCESS		
	Preliminary instructions.....	6	3
	Equipment setup	7	3
	Oscillator	8	4
	Final procedure.....	9	5

*This bulletin supersedes TB 9-6625-2307-35, 2 Feb 1994.

**SECTION I
IDENTIFICATION AND DESCRIPTION**

1. Test Instrument Identification. This bulletin provides instructions for the calibration of Data Communications Analyzer, TS-4281/G and Model TS-4465/G. TM 11-6625-3264-40 was used as the prime data source in compiling these instructions. The equipment being calibrated will be referred to as the TI (test instrument) throughout this bulletin.

a. Model Variations. None.

b. Time and Technique. The time required for this calibration is approximately 1 hour, using the dc and low frequency technique.

2. Forms, Records, and Reports

a. Forms, records, and reports required for calibration personnel at all levels are prescribed by TB 750-25.

b. Adjustments to be reported are designated (R) at the end of the sentence in which they appear. When adjustments are in tables, the (R) follows the designated adjustment. Report only those adjustments made and designated with (R).

3. Calibration Description. TI parameters and performance specifications which pertain to this calibration are listed in table 1.

Table 1. Calibration Description

Test instrument parameters	Performance specifications
Oscillator	Range: 12 MHz Accuracy: ±5 ppm

**SECTION II
EQUIPMENT REQUIREMENTS**

4. Equipment Required. Table 2 identifies the specific equipment to be used in this calibration procedure. This equipment is issued with Secondary Transfer Calibration Standards Set AN/GSM-286, AN/GSM-287, or AN/GSM-705. Alternate items may be used by the calibrating activity. The items selected must be verified to perform satisfactorily prior to use and must bear evidence of current calibration. The equipment must meet or exceed the minimum use specifications listed in table 2. The accuracies listed in table 2 provide a four-to-one ratio between the standard and TI.

5. Accessories Required. The accessories required for this calibration are common usage accessories issued as indicated in paragraph 4 above and are not listed in this calibration procedure. The following peculiar accessory is required for this calibration: Extender card, P/N 80-41755-01 (AB08).

Table 2. Minimum Specifications of Equipment Required

Common name	Minimum use specifications	Manufacturer and model (part number)
FREQUENCY COUNTER	Range: 12 MHz Accuracy: ± 1.25 ppm	Fluke, Model PM6681/656 (PM6681/656)

**SECTION III
CALIBRATION PROCESS**

6. Preliminary Instructions

a. The instructions outlined in paragraphs 6 and 7 are preparatory to the calibration process. Personnel should become familiar with the entire bulletin before beginning the calibration.

b. Items of equipment used in this procedure are referenced within the text by common name as listed in table 2.

c. Unless otherwise specified, verify the results of each test and, whenever the test requirement is not met, take corrective action before continuing with the calibration. Adjustments required to calibrate TI are included in this procedure. Additional maintenance information is contained in TM 11-6625-3264-40.

d. Unless otherwise specified, all controls and control settings refer to the TI.

7. Equipment Setup

WARNING

HIGH VOLTAGE is used or exposed during the performance of this calibration. DEATH ON CONTACT may result if personnel fail to observe safety precautions. REDUCE OUTPUT(S) to minimum after each step within the performance check where applicable.

a. Remove protective cover from TI only when necessary to make adjustments. Replace cover after completing the adjustments.

b. Ensure rear panel voltage select card is set for 115 V ac. Connect TI to an appropriate 115 V ac source.

c. Set **POWER** switch to **ON**. Allow approximately 10 minutes warm-up period.

8. Oscillator

a. Performance Check

- (1) Initialize TI by performing (a) through (c) below:
 - (a) Press **MENU** key to select **AUXILIARY**.
 - (b) Enter **43** from key pad, followed by **ENTER**.
 - (c) Clear **NOVRAM** by pressing left soft key (**YES**); then center soft key (**YES**).
- (2) Connect rear panel **GEN CLK OUT** to frequency counter.
- (3) Scroll the **MENU** to **SYNTH FREQ**.
- (4) Enter **12000**, followed by **ENTER** to select 12 MHz.
- (5) Measure frequency.
- (6) If frequency counter does not indicate between 11.999940 and 12.000060 MHz, perform **b** below.

b. Adjustments

- (1) Remove rear panel.
 - (a) Set **POWER** switch to **OFF**; then disconnect power cable from TI.
 - (b) Remove 16 screws from rear (fig. 1).
 - (c) Gently pry rear panel loose from chassis and disconnect **FAN CABLE** (fig. 1)
- (2) Install extender card.
 - (a) Remove **PROCESSOR CIRCUIT CARD** (fig. 1).
 - (b) Install extender card and connect **PROCESSOR CIRCUIT CARD** to extender card.
 - (c) Reconnect power cable to TI (and to ac source) and set **POWER** switch to **ON**.
- (3) Repeat technique of **a** (1) through (5) above.

- (4) Adjust Y1 (fig. 1) for a 12.0 MHz (± 10 Hz) indication on frequency counter (R).
- (5) Reassemble TI and repeat a above.

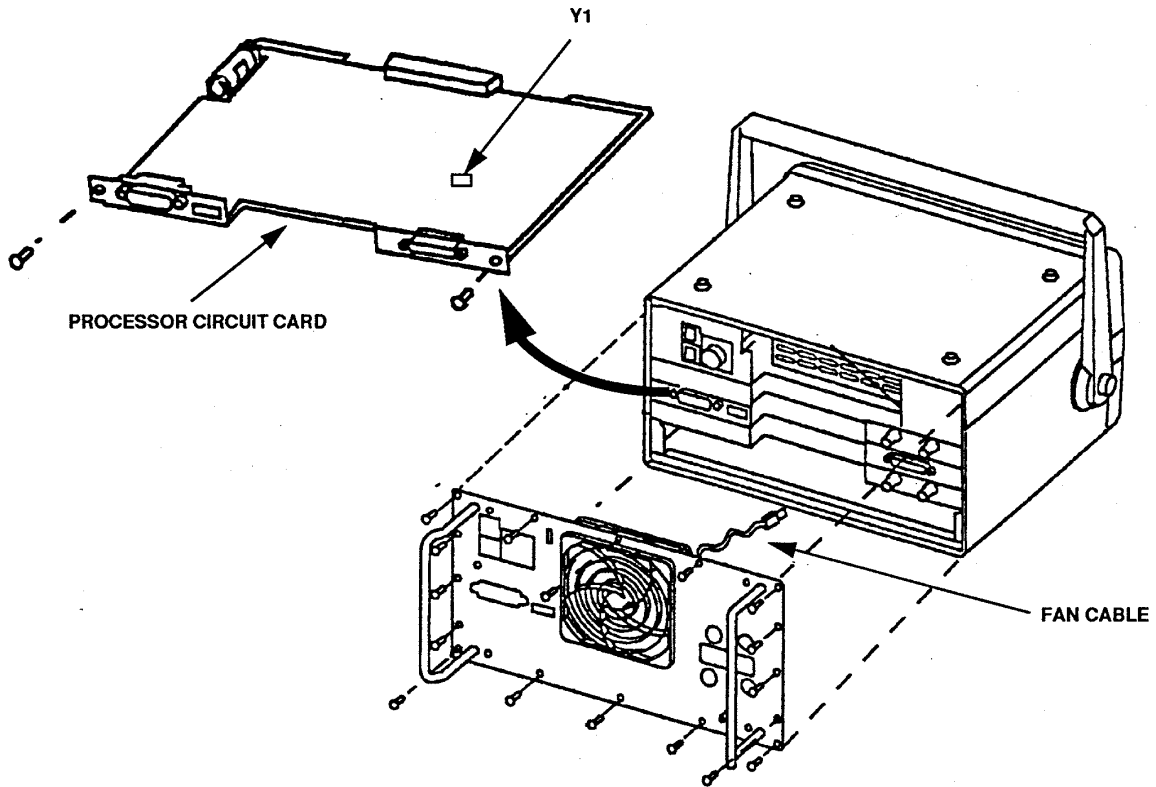

Figure 1. Adjustment.

9. Final Procedure

- a. Deenergize and disconnect all equipment.
- b. Annotate and affix DA label/form in accordance with TB 750-25.

By Order of the Secretary of the Army:

Official:



JOEL B. HUDSON

*Administrative Assistant to the
Secretary of the Army*

0400504

PETER J. SCHOOMAKER

*General, United States Army
Chief of Staff*

Distribution:

To be distributed in accordance with the initial distribution number (IDN) 344510 requirements
TB 9-6625-2307-35.

Instructions for Submitting an Electronic 2028

The following format must be used if submitting an electronic 2028. The subject line must be exactly the same and all fields must be included; however, only the following fields are mandatory: 1, 3, 4, 5, 6, 7, 8, 9, 10, 13, 15, 16, 17, and 27.

From: "Whomever" whomever@redstone.army.mil
To: <2028@redstone.army.mil

Subject: DA Form 2028

1. **From:** Joe Smith
2. **Unit:** home
3. **Address:** 4300 Park
4. **City:** Hometown
5. **St:** MO
6. **Zip:** 77777
7. **Date Sent:** 19-OCT -93
8. **Pub no:** 55-2840-229-23
9. **Pub Title:** TM
10. **Publication Date:** 04-JUL-85
11. **Change Number:** 7
12. **Submitter Rank:** MSG
13. **Submitter FName:** Joe
14. **Submitter MName:** T
15. **Submitter LName:** Smith
16. **Submitter Phone:** 123-123-1234
17. **Problem:** 1
18. **Page:** 2
19. **Paragraph:** 3
20. **Line:** 4
21. **NSN:** 5
22. **Reference:** 6
23. **Figure:** 7
24. **Table:** 8
25. **Item:** 9
26. **Total:** 123
27. **Text**

This is the text for the problem below line 27.

